

# SUBMITTAL

**Manufacturer:** Itron  
(formerly Actaris/Schlumberger)  
**Model:** B42

As Specified	
Capacity Required	
Inlet /Outlet Pres.	
Overpres. Limits	

As Submitted	
Capacity	
Drop	
Build-up	

**Options Designations:**

**N:** Denotes No Internal Relief

**R:** denotes Internal Relief valve for over-pressure protection

**Specifications:**

	Spring Color	Adj. Range		Orifice	MAOP PSIG	Connections (NPT)	
						Inlet	Outlet
	Dk Green (31)	6 – 16" w.c.		1/8"	125	1/2"	1/2"
	Green	5 – 7" w.c.		1/8" x 3/16"	125	1/2"	3/4"
	Brown	6 – 8" w.c.		3/16"	125	1/2"	1"
	Blue	8 – 14" w.c.		1/4"	60	3/4"	3/4"
	Silver	12 – 28" w.c.		5/16"	35	3/4"	1"
	Yellow/Blk	1 – 2 PSIG		3/8"	20	3/4"	1 1/4"
	Yellow	2 – 4 PSIG		1/2"	10	1"	1"
	White	4 – 5 PSIG		1/2" x 9/16"	10	1"	1 1/4"
						1 1/4"	1 1/4"

**Assembly:**

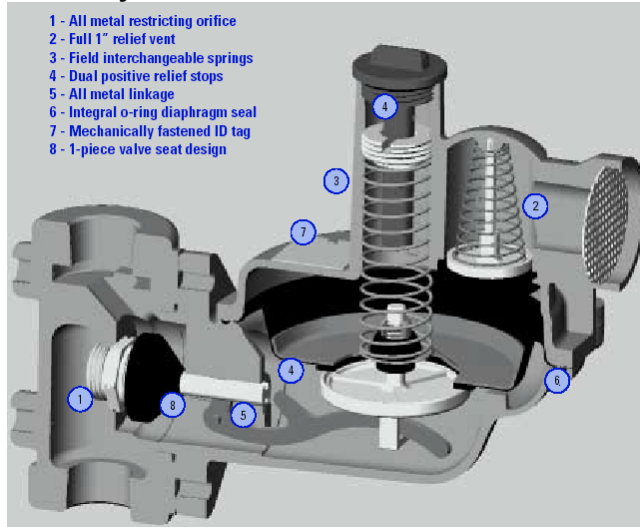

**Dimensions:**

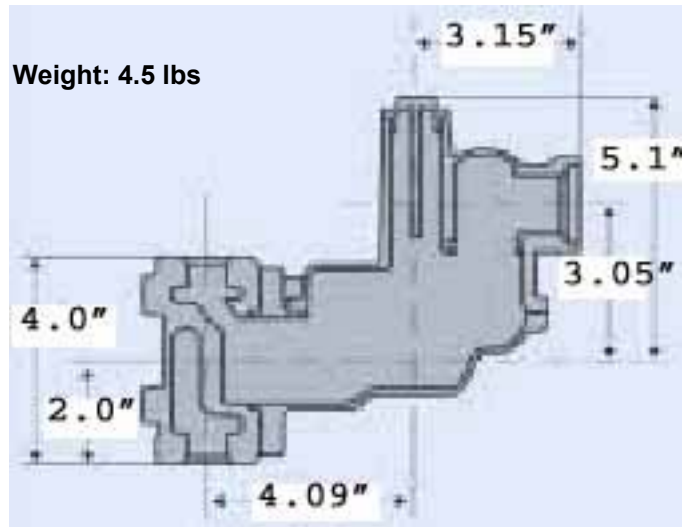

**General Note on installation:** The regulator comes with a 3/4" or 1" vent with stainless steel vent screen. On outside installations, the regulator should be oriented with the vent pointing down to keep water or ice from entering the vent. If the regulator is installed with the vent pointing up or to the side, the vent screen should be removed and a 3/4" x 1" elbow (or elbows) should be installed to position the vent correctly. If installed inside, the vent must be piped to a safe outside location in accordance with NFPA 54 recommendations.

**Typical Capacity.**

Note: Capacity will change as a function of the orifice size, inlet pressure & outlet pressure setting. The capacity tables below are for a typical configuration: a 1" Regulator, with 1/2" orifice. Smaller orifices may have less capacity, but will handle higher inlet pressures (see MAOP above). Consult complete product bulletin for capacities and relief curves of other configurations.

**MA Approval #** G1-0206-14, G3-0207-278, G3-0110-299 (expires 1/16/2013)

Set Point	Capacity as a Function of Inlet Pressure & Set Point				
	14" w.c.	1 PSIG	2 PSIG	5 PSIG	10 PSIG
7" w.c.	270	400	600	1100	1550
11" w.c.	220	485	725	1174	1581
14" w.c.		550	820	1230	1605

Capacities expressed for 0.6 s.g. nat. gas

v.04

